

1 Customer drawings

NOTE:

1,	DESCRIPTION	Q'ty	MATERIAL	PLATING
01	QSFP CAGE	1PCS	STAINLESS STEEL T=0.25	N/A
02	EMI FINGERS	10PCS	COPPER ALLOY T=0.06	NI FOR ALL
03	HEATSINK CLIP	3PCS	STAINLESS STEEL T=0.25	N/A
04	HEATSINK	3PCS	AL&CU	NI FOR ALL
05	MYLAR	1PCS	PET T=0.20	N/A

2, TEMPERATURE:  
 OPERATION: -40°C~+105°C  
 STORAGE: -10°C~+60°C

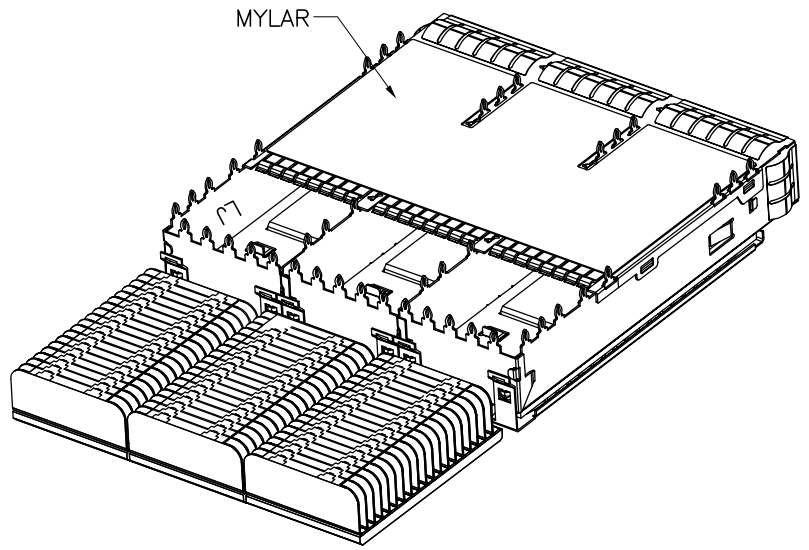
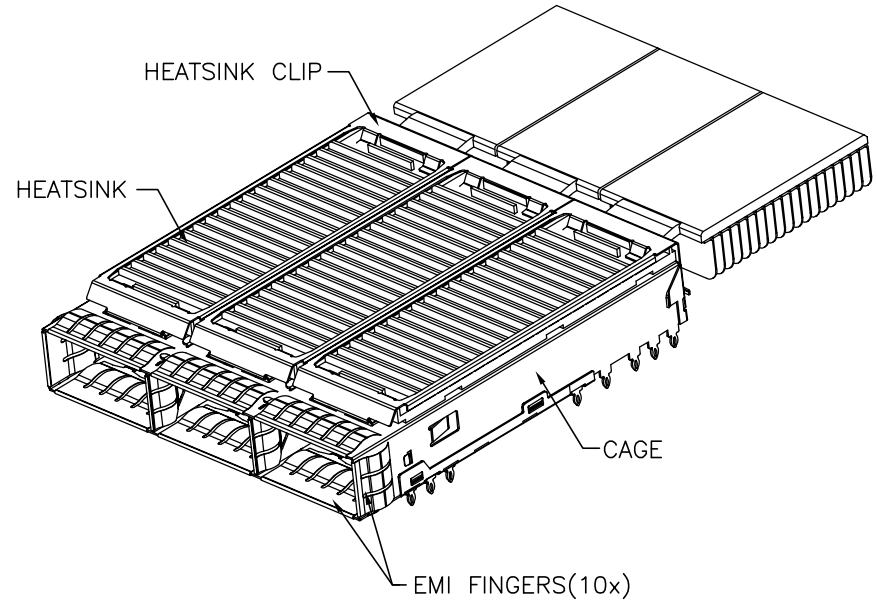

A	NEW RELEASED		Shmily
版次	修改说明	ECN 编号	核准

自由公差				设计	
长度尺寸		角度尺寸			
X.	±0.25	X°	±0.5°	设计	
.XX	±0.25	.X°	±0.5°	审核	
.XX	±0.20	.XX°	±0.5°	核准	
.XXX	±0.15				
单位	mm	比例	1:1		
A4	☉	页次	1 of 4		

**ETLINK** 深圳市益晟康科技有限公司  
 SHENZHEN ETLINK TECHNOLOGY CO.,LTD

品名	高速接口28G 19.00mm 1x3 CAGE带散热片
料号	81-163-00004-1
图号	E8116090701-C
版本:	A

Customer drawings

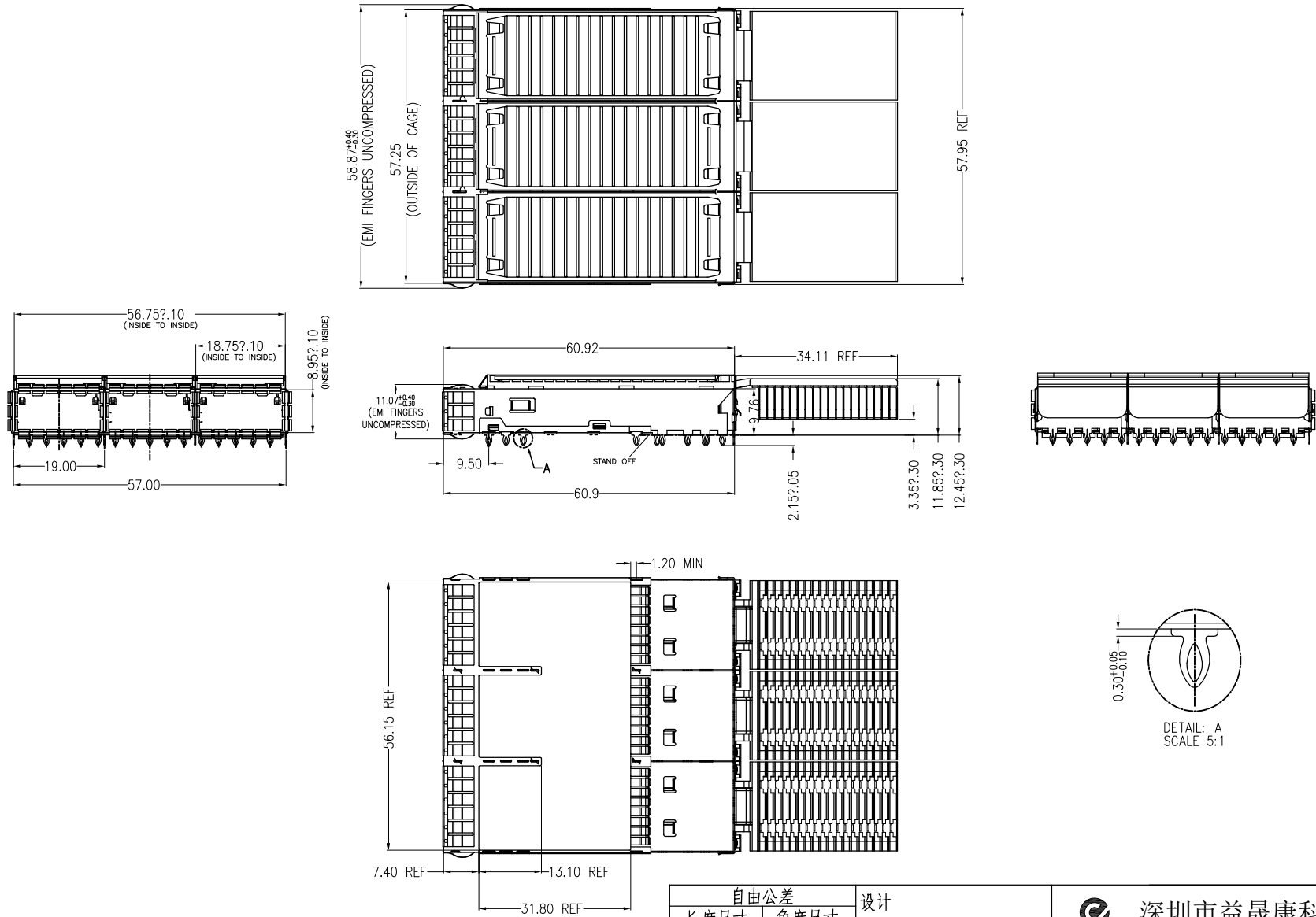

A	NEW RELEASED		Shmily
版次	修改说明	ECN 编号	核准

自由公差			
长度尺寸		角度尺寸	
X.	±0.25	X°	±0.5°
.X	±0.25	.X°	±0.5°
.XX	±0.20	.XX°	±0.5°
.XXX	±0.15		
单位	mm	比例	1:1
A4	页次	2 of 4	

设计  
审核  
核准

**ETLINK** 深圳市益晟康科技有限公司  
SHENZHEN ETLINK TECHNOLOGY CO.,LTD

品名	高速接口28G 19.00mm 1x3 CAGE带散热片
料号	81-163-00004-1
图号	E8116090701-C
版本:	A

1  
Customer drawings

RECOMMENDED BEZEL CUT-OUT SINGLE SIDED APPLICATIONS

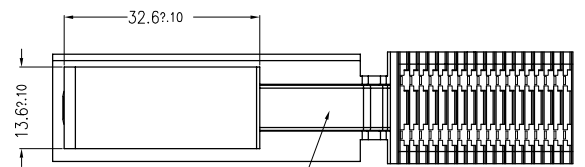
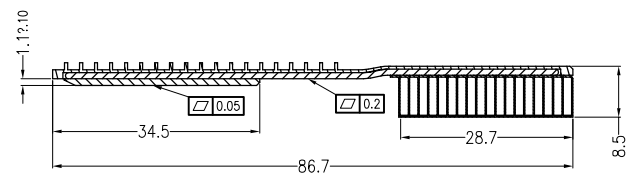
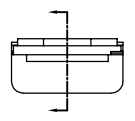
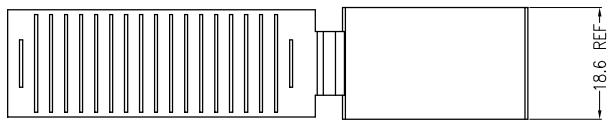
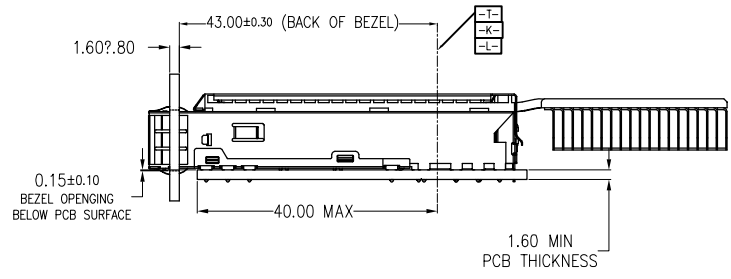
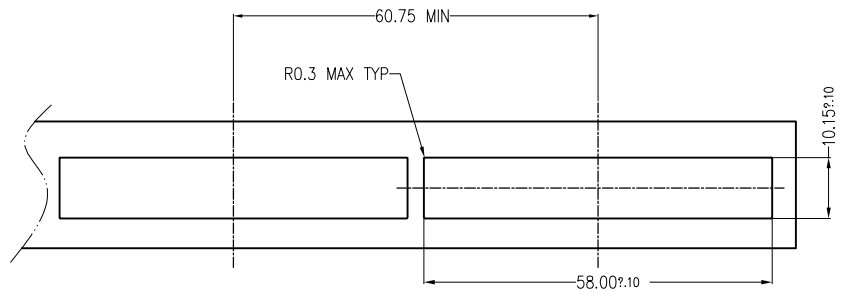

热管不超出基板

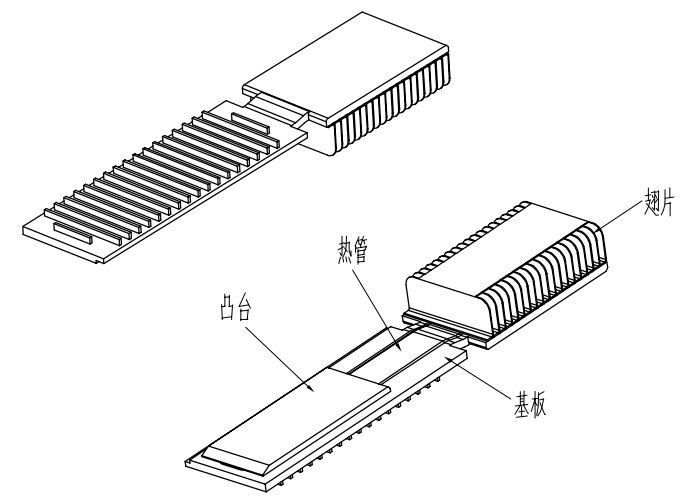

A	NEW RELEASED	Shmily	
版次	修改说明	ECN 编号	核准

自由公差			
长度尺寸		角度尺寸	
X.	±0.25	X'	±0.5'
.X	±0.25	.X'	±0.5'
.XX	±0.20	.XX'	±0.5'
.XXX	±0.15		
单位	mm	比例	1:1
A4		页次	3 of 4

设计  
审核  
核准

**ETLINK** 深圳市益晟康科技有限公司  
SHENZHEN ETLINK TECHNOLOGY CO.,LTD

品名	高速接口28G 19.00mm 1x3 CAGE带散热片
料号	81-163-00004-1
图号	E8116090701-C
版本:	A

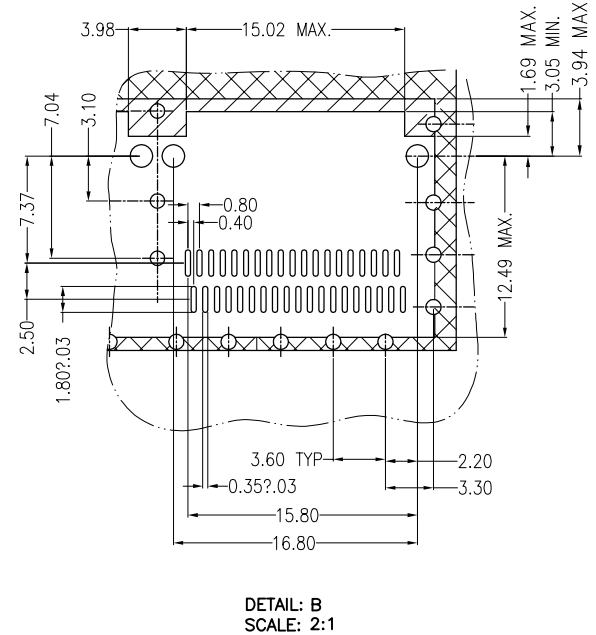
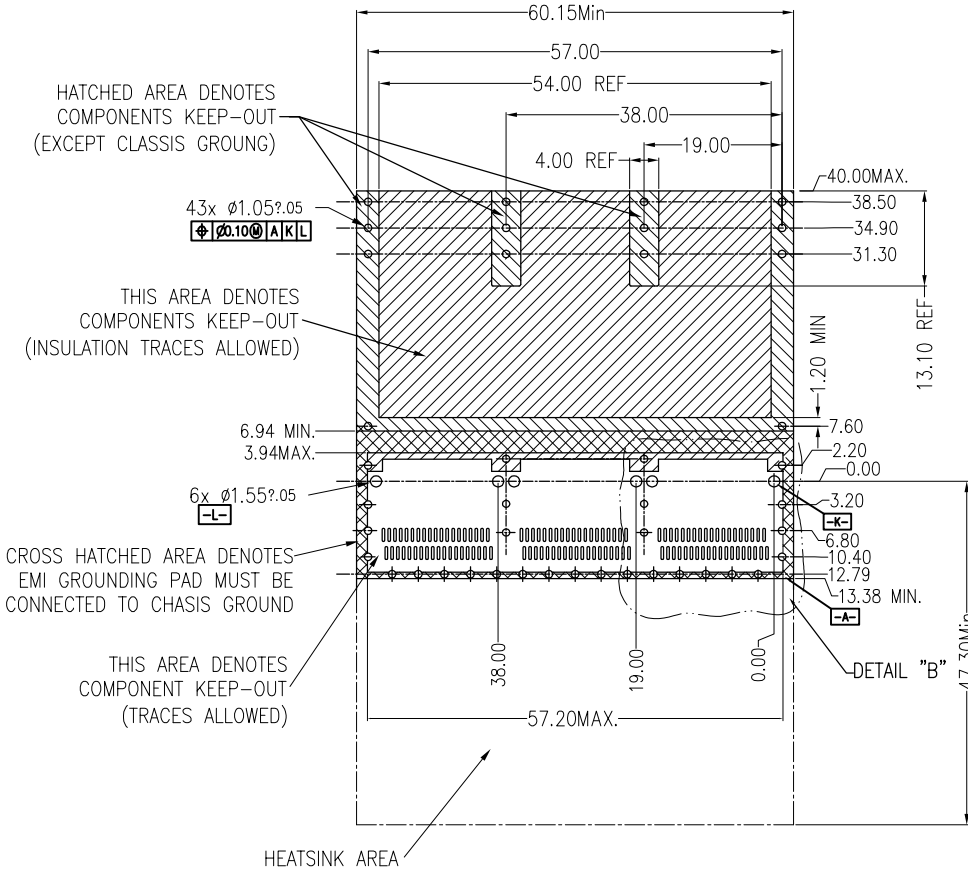

- NOTES:
- SEE QSFP MSA SPECIFICATION FOR BEZEL LOCATION TOLERANCE
  - DATUM -A- IS TIP SURFACE OF HOST BOARD PER MSA
  - FINISHED HOLE SIZE (AFTER PLATING)
  - DATUM -K- IS HOST BOARD THRE HOLE #1 TO ACCEPT CONNECTOR GUIDE POST PER MSA
  - DATUM -L- IS HOST BOARD THRE HOLE #2 TO ACCEPT CONNECTOR GUIDE POST PER MSA
  - DATUM -T- IS HARD STOP ON CAGE PER MSA

				自由公差		设计		深圳市益晟康科技有限公司 ETLINK SHENZHEN ETLINK TECHNOLOGY CO.,LTD	
				长度尺寸	角度尺寸	审核			
				.X	±0.25	.X°	±0.5°	品名	
				.XX	±0.25	.X°	±0.5°	料号	
				.XX	±0.20	.XX°	±0.5°	图号	
				.XXX	±0.15			版本: A	
A	NEW RELEASED		Shmily	单位	mm	比例	1:1	核准	
版次	修改说明	ECN 编号	核准	A4	页次	4 of 4			