

Customer drawings

NOTE:

1, DESCRIPTION	Q'ty	MATERIAL	PLATING
SFP TOP CAGE	1PCS	COPPER ALLOY T=0.25	N/A
SFP BOTTOM CAGE	1PCS	COPPER ALLOY T=0.25	N/A
SFP MID CAGE	3PCS	COPPER ALLOY T=0.25	N/A
SFP KICKOUT SPRING	1PCS	COPPER ALLOY T=0.20	N/A
SFP EMI SPRINGS(top)	1PCS	COPPER ALLOY T=0.06	TIN OVER NICKEL
SFP EMI SPRINGS(side)	2PCS	COPPER ALLOY T=0.06	TIN OVER NICKEL
SFP EMI SPRINGS(bottom)	1PCS	COPPER ALLOY T=0.08	TIN OVER NICKEL

2, TEMPERATURE:

OPERATION: -40°C~+85°C
STORAGE: -55°C~+105°C

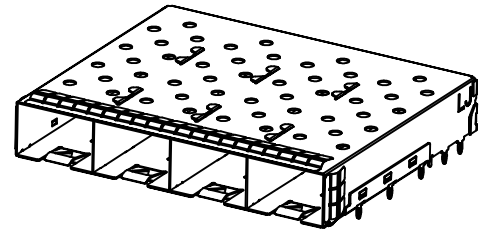
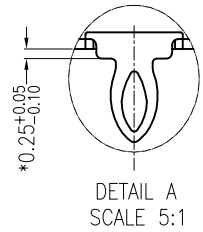
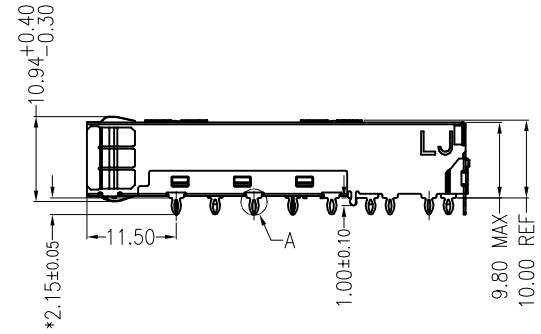
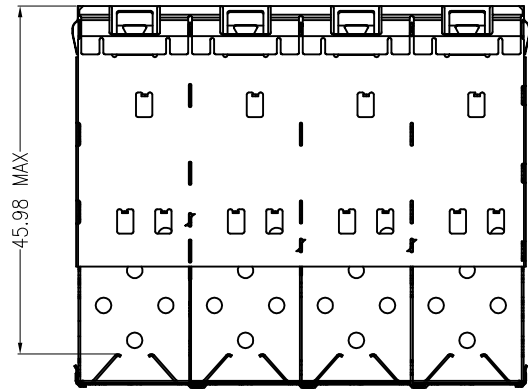
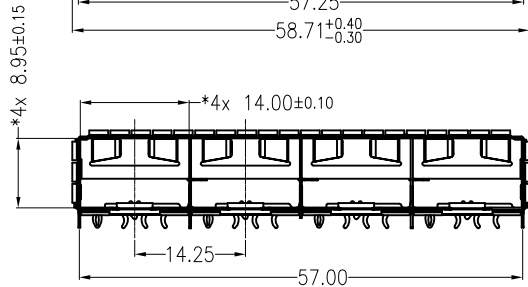
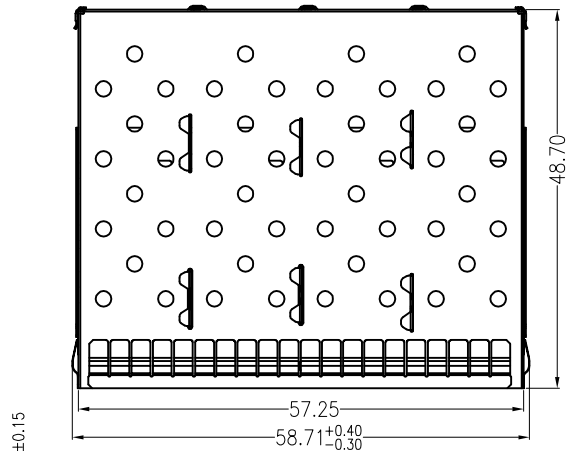

自由公差				设计		深圳市益晟康科技有限公司				
长度尺寸	角度尺寸			Lemon	2017.10.24	ETLINK SHENZHEN ETLINK TECHNOLOGY CO.,LTD				
X. ±0.25	X. ±0.5°			审核	Linson	2017.10.24	品名	SFP+ 1×4 CAGE		
.X ±0.25	.X ±0.5°						料号	81-114-00002-1		
.XX ±0.20	.XX ±0.5°						图号	ESFP14030504-C	版本:	A
.XXX ±0.15	.XXX ±0.5°									
单位	mm	比例	1:1	核准	Shmily	2017.10.24				
版次	修改说明	ECN 编号	核准	A4	页次	1 of 3				

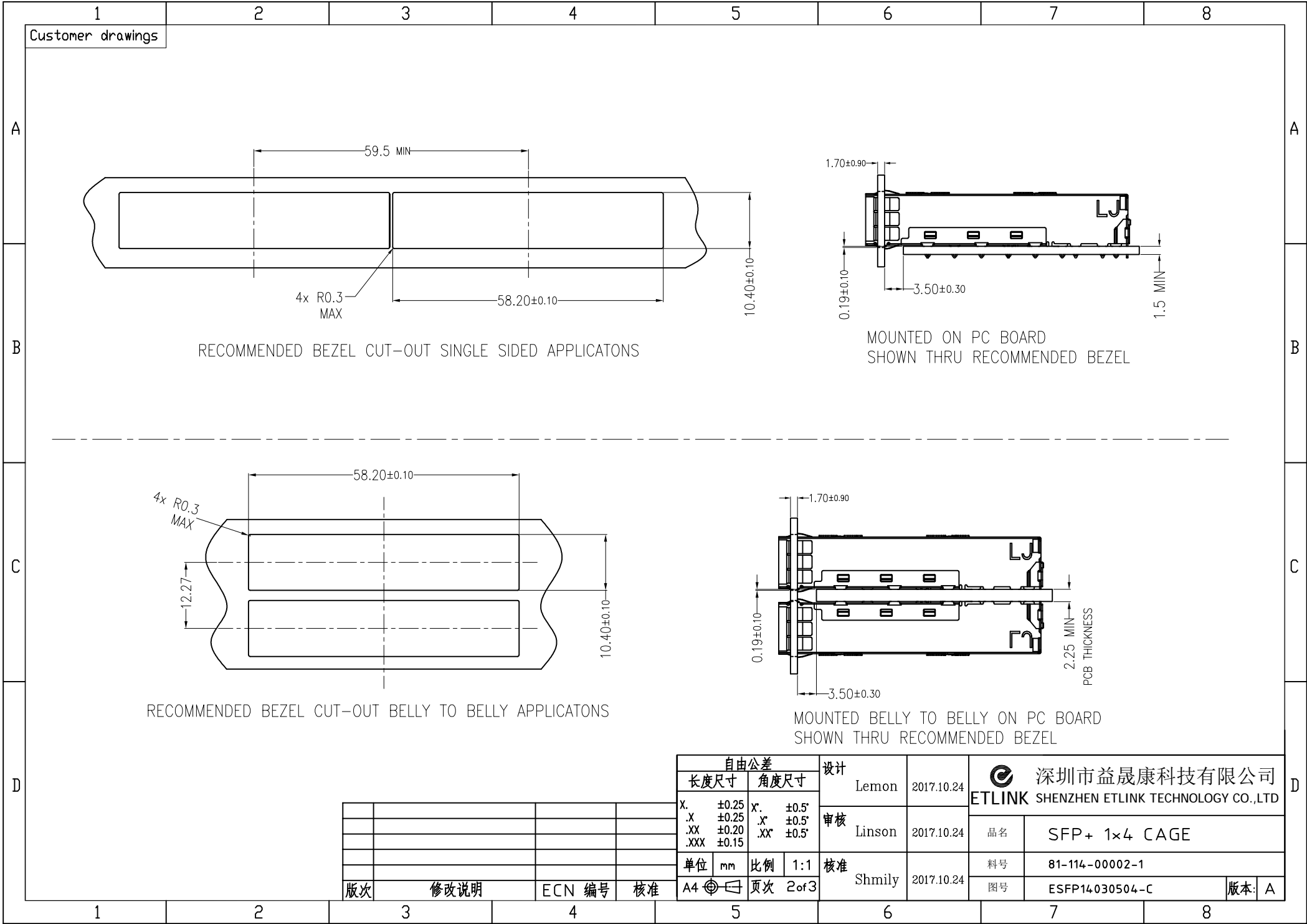

RECOMMENDED BEZEL CUT-OUT SINGLE SIDED APPLICATIONS

MOUNTED ON PC BOARD
SHOWN THRU RECOMMENDED BEZEL

RECOMMENDED BEZEL CUT-OUT BELLY TO BELLY APPLICATIONS

MOUNTED BELLY TO BELLY ON PC BOARD
SHOWN THRU RECOMMENDED BEZEL

				自由公差		设计		深圳市益晟康科技有限公司		
				长度尺寸	角度尺寸	Lemon	2017.10.24	ETLINK SHENZHEN ETLINK TECHNOLOGY CO.,LTD		
				X. ±0.25	X° ±0.5°	审核	Linson	2017.10.24	品名	SFP+ 1×4 CAGE
			.X ±0.25	.X° ±0.5°	料号				81-114-00002-1	
			.XX ±0.20	.XX° ±0.5°	核准	Shmily	2017.10.24	图号	ESFP14030504-C	版本: A
			.XXX ±0.15					图号	ESFP14030504-C	版本: A
单位	mm	比例	1:1	核准	Shmily	2017.10.24				
版次	修改说明	ECN 编号	核准	A4	页次	2 of 3				

Customer drawings

RECOMMENDED PCB CONFIGURATION WITH KEEP-OUT AREAS
SINGLE SIDED APPLICATIONS

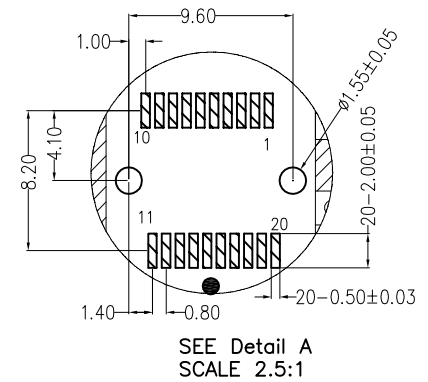
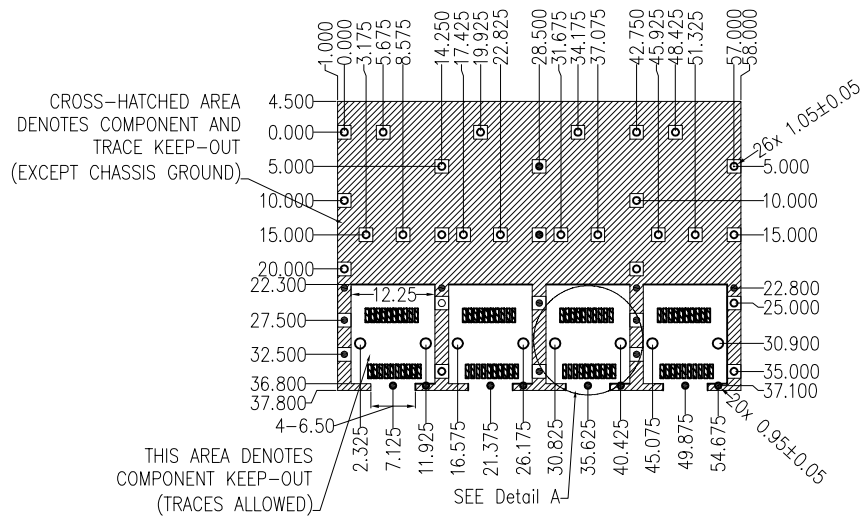

RECOMMENDED PCB CONFIGURATION WITH KEEP-OUT AREAS
BELLY TO BELLY APPLICATIONS

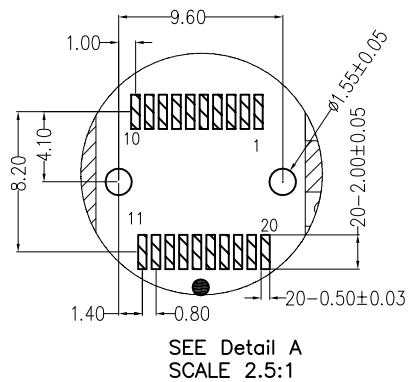
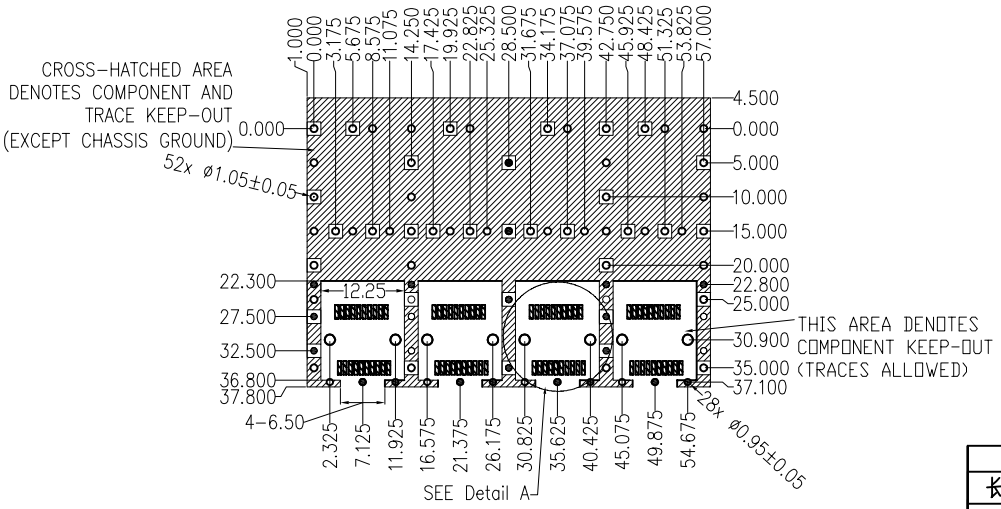

自由公差				设计	2017.10.24	深圳市益晟康科技有限公司 ETLINK SHENZHEN ETLINK TECHNOLOGY CO.,LTD	
长度尺寸	角度尺寸	设计	2017.10.24				
X. ±0.25	X. ±0.5°	审核	Linson	2017.10.24	品名	SFP+ 1x4 CAGE	
.X ±0.25	.X ±0.5°	核准	Shmily	2017.10.24	料号	81-114-00002-1	
.XX ±0.20	.XX ±0.5°				图号	ESFP14030504-C	
.XXX ±0.15					版本	A	
单位	mm	比例	1:1	核次			
A4	⊕	页次	3 of 3				

版次	修改说明	ECN 编号	核准