

Customer drawings

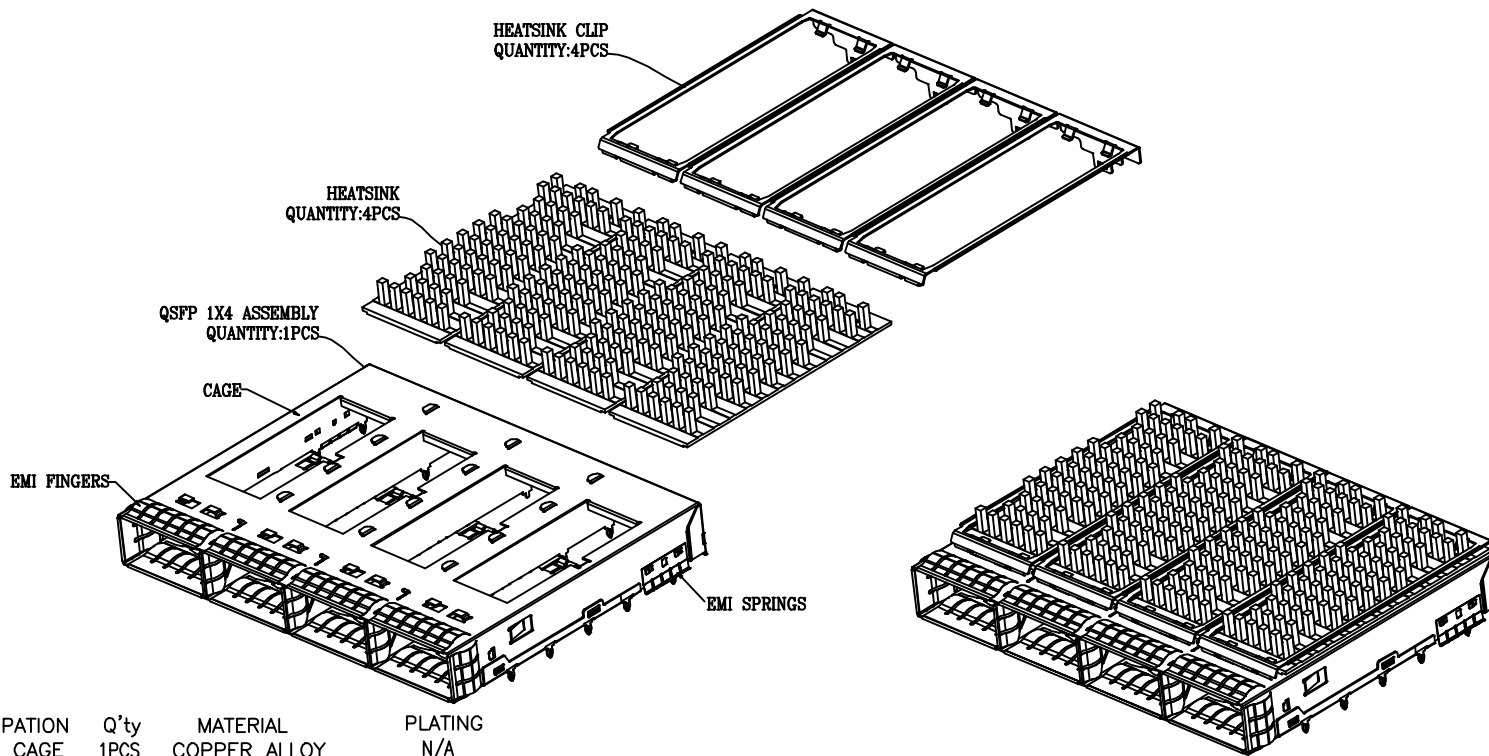

NOTE:

1,	DESCRIPTION	Q'ty	MATERIAL	PLATING
01	QSFP CAGE	1PCS	COPPER ALLOY	N/A
02	EMI FINGERS	13PCS	COPPER ALLOY	NI FOR ALL
03	EMI SPRINGS	6PCS	COPPER ALLOY	N/A
04	HEATSINK CLIP	4PCS	STAINLESS STEEL	N/A
05	HEATSINK	4PCS	AL	ANODIZE BLACK

2, TEMPERATURE:  
 OPERATION: -40°C~+85°C  
 STORAGE: -55°C~+105°C

版次	修改说明	ECN 编号	核准

自由公差			
长度尺寸		角度尺寸	
X.	±0.25	X°	±0.5°
.X	±0.25	.X°	±0.5°
.XX	±0.20	.XX°	±0.5°
.XXX	±0.15		
单位	mm	比例	1:1
A4	⊕	页次	1 of 4

设计
审核
核准

<b>深圳市益晟康科技有限公司</b> <b>ETLINK SHENZHEN ETLINK TECHNOLOGY CO.,LTD</b>	
品名	QSFP+ 1x4 CAGE WITH HEATSINK
料号	81-134-00008-1
图号	E8116121904-C
版本	X1

Customer drawings

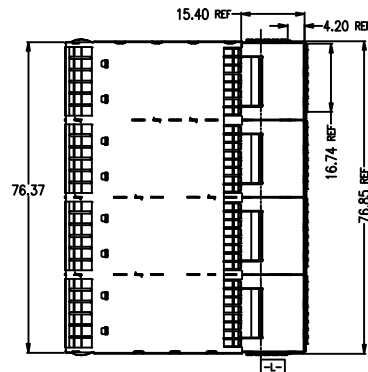
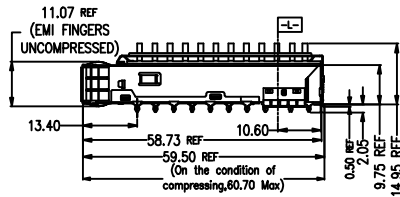
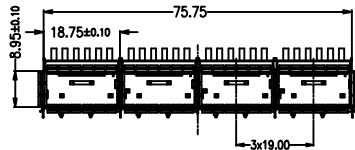
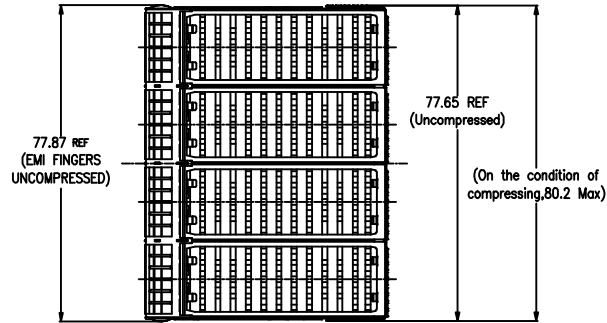

版次	修改说明	ECN 编号	核准		

自由公差		设计	
长度尺寸	角度尺寸		
X. ±0.25	X° ±0.5'	审核	
.X ±0.25	.X° ±0.5'		
.XX ±0.20	.XX° ±0.5'		
.XXX ±0.15	.XXX° ±0.5'		
单位	mm	比例	1:1
A4		页次	2 of 4

<b>深圳市益晟康科技有限公司</b> <b>ETLINK SHENZHEN ETLINK TECHNOLOGY CO.,LTD</b>	
品名	QSFP+ 1x4 CAGE WITH HEATSINK
料号	81-134-00008-1
图号	E8116121904-C
版本	X1

Customer drawings

PCB LAYOUT FOR SINGLE SIDED APPLICATION

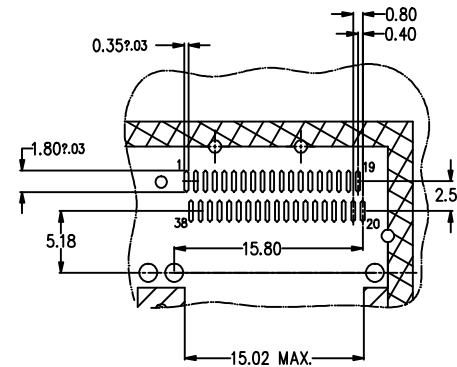
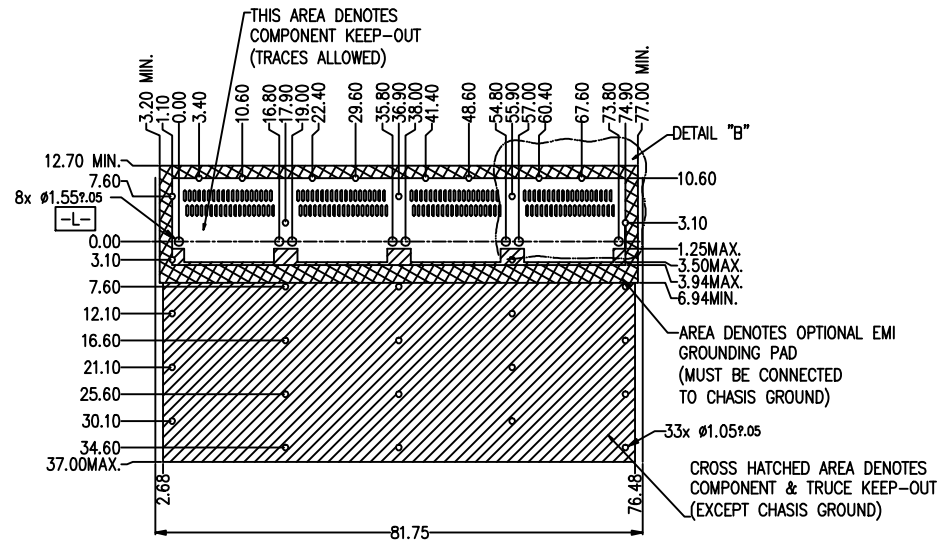
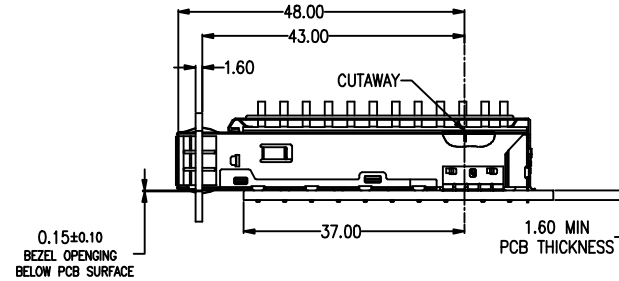
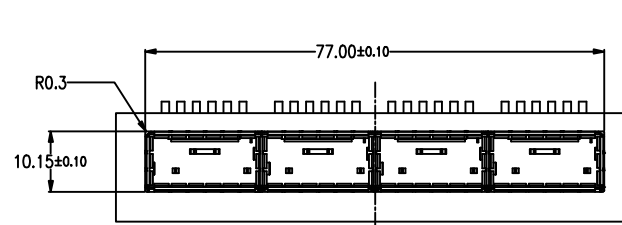

DETAIL: B  
SCALE: 2:1

版次	修改说明	ECN 编号	核准

自由公差		设计
长度尺寸	角度尺寸	
X.	±0.25	审核
.X	±0.25	
.XX	±0.20	
.XXX	±0.15	
单位	mm	核准
比例	1:1	
A4	页次 3 of 4	

**深圳市益晟康科技有限公司**  
**ETLINK SHENZHEN ETLINK TECHNOLOGY CO.,LTD**

品名	QSFP+ 1x4 CAGE WITH HEATSINK
料号	81-134-00008-1
图号	E8116121904-C
版本	X1

