

1
Customer drawings

NOTE:
 1, DESCRIPTION Q'ty MATERIAL PLATING
 SFP CAGE 1PCS COPPER ALLOY N/A
 SFP EMI CLIP 4PCS COPPER ALLOY TIN PLATE OVER NICKEL
 HEATSINK CLIP 6PCS STAINLESS STEEL N/A
 HEATSINK 6PCS AL NI FOR ALL
 2, TEMPERATURE:
 OPERATION: -40°C~+85°C
 STORAGE: -55°C~+105°C

HEATSINK CLIP
QUANTITY:6PCS

HEATSINK
QUANTITY:6PCS

QSFP 1X4 ASSEMBLY
QUANTITY:1PCS

CAGE

EMI CLIP

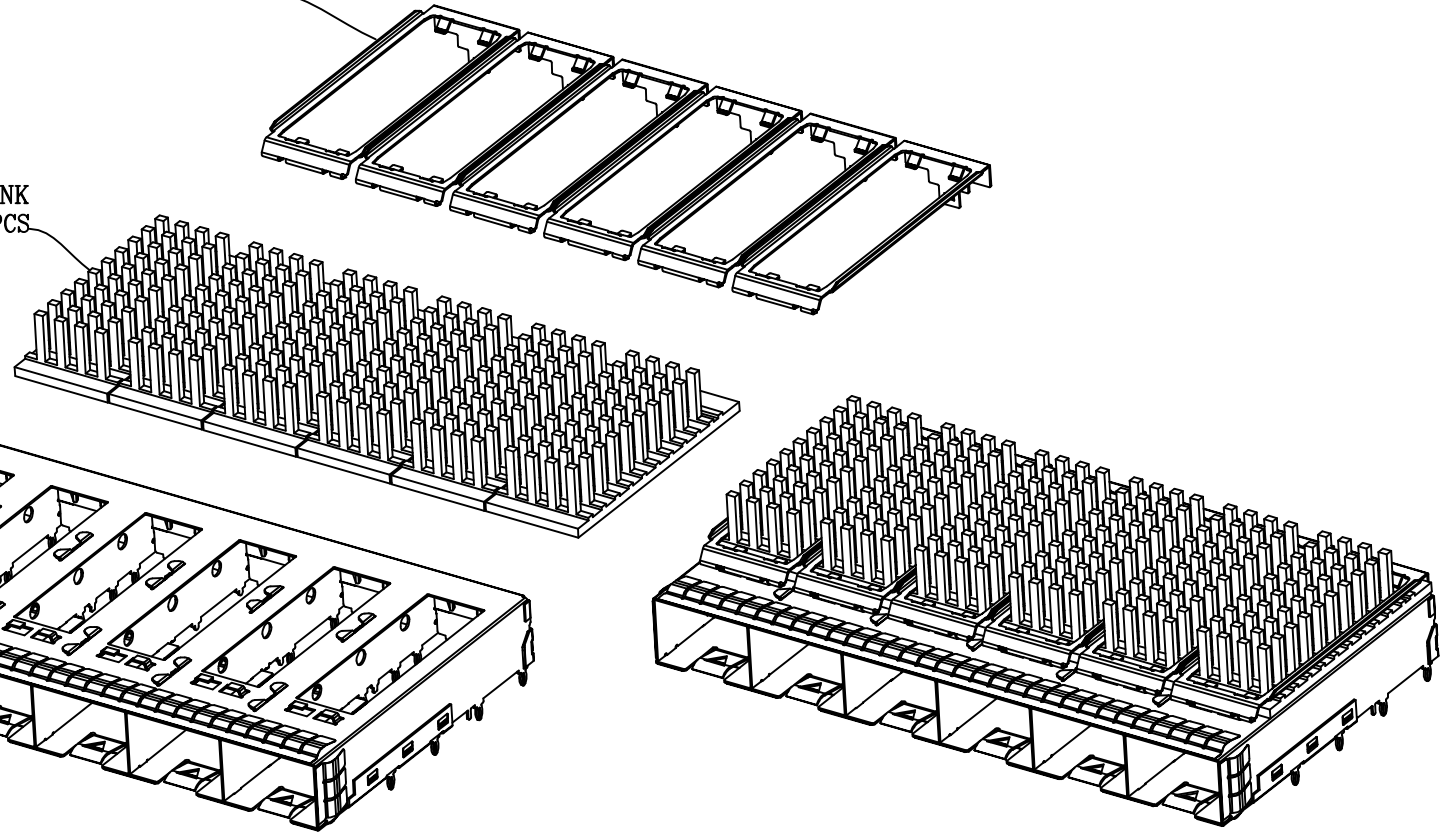

自由公差		设计		深圳市益晟康科技有限公司 ETLINK SHENZHEN ETLINK TECHNOLOGY CO.,LTD	
长度尺寸	角度尺寸	审核			
X. ±0.25	X° ±0.5°	核准		品名	SFP+ 1x6 CAGE WITH HEATSINK
.X ±0.25	.X° ±0.5°			料号	81-116-00012-1
.XX ±0.20	.XX° ±0.5°	单位	mm	比例	1:1
.XXX ±0.15		图号	E81151214 01-C		版本: X2
X2	update drawings	/	NEIL	A4 页次 1 of 5	
版次	修改说明	ECN 编号	核准		

A
B
C
D

A
B
C
D

1 2 3 4 5 6 7 8

Customer drawings

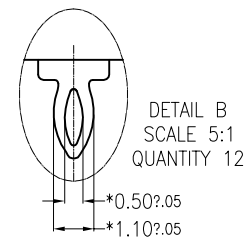
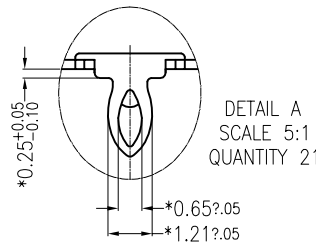
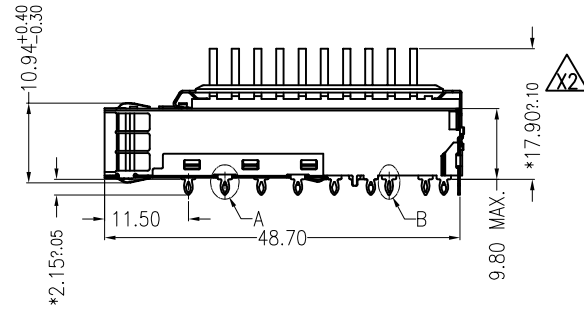
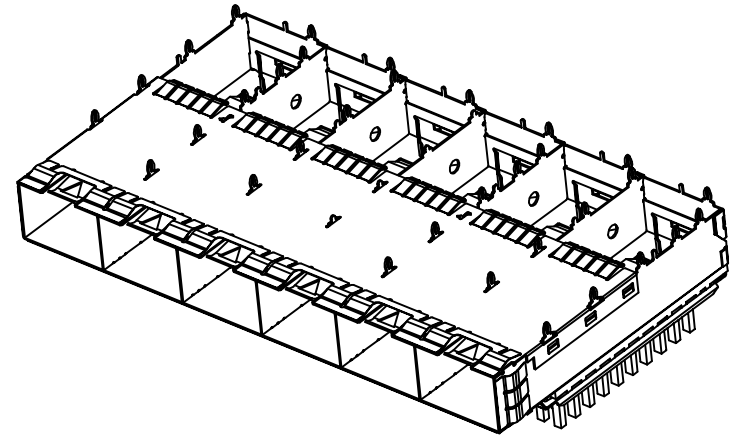
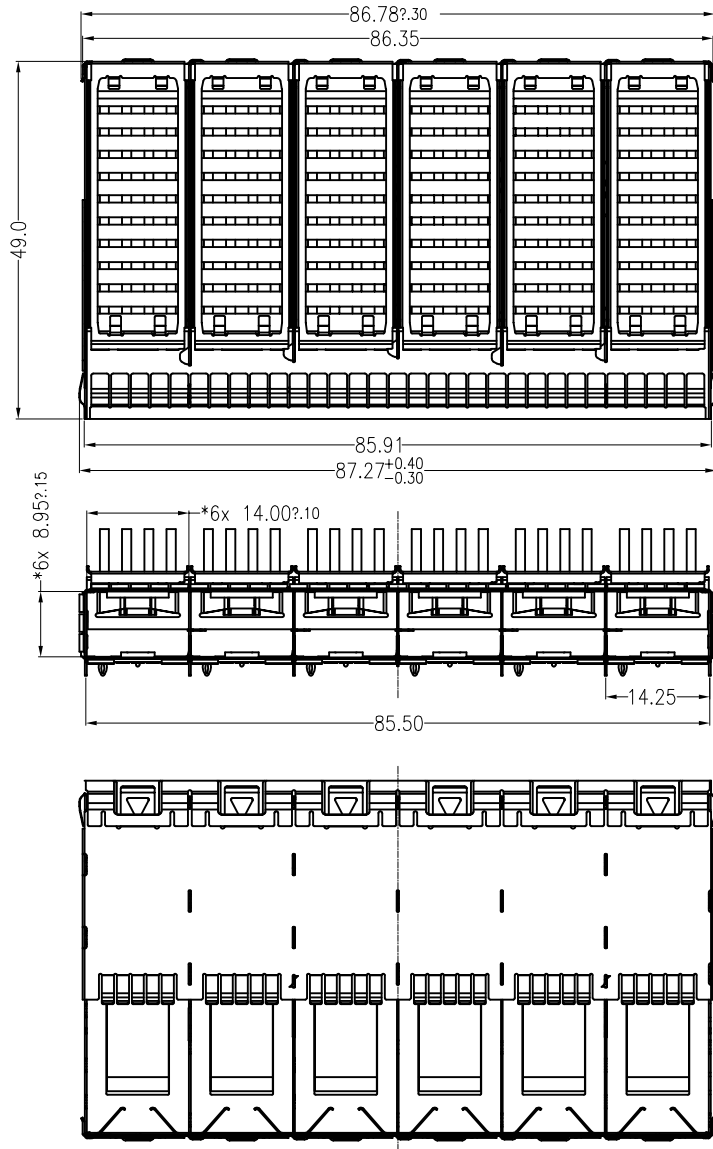

X2	update drawings	/	NEIL
版次	修改说明	ECN 编号	核准

自由公差		设计	深圳市益晟康科技有限公司 ETLINK SHENZHEN ETLINK TECHNOLOGY CO.,LTD			
长度尺寸	角度尺寸					
X	±0.25	审核	品名	SFP+ 1x6 CAGE WITH HEATSINK		
.X	±0.25					
.XX	±0.20					
.XXX	±0.15	核准	料号	81-116-00012-1		
单位	mm				比例	1:1
A4	页次					
			图号	E81151214 01-C	版本: X2	

Customer drawings

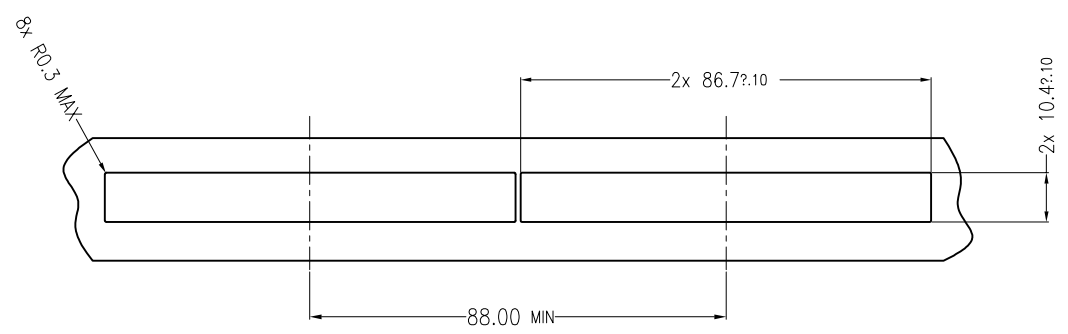

RECOMMENDED BEZEL CUT-OUT SINGLE SIDED APPLICATIONS
SCALE 5:3

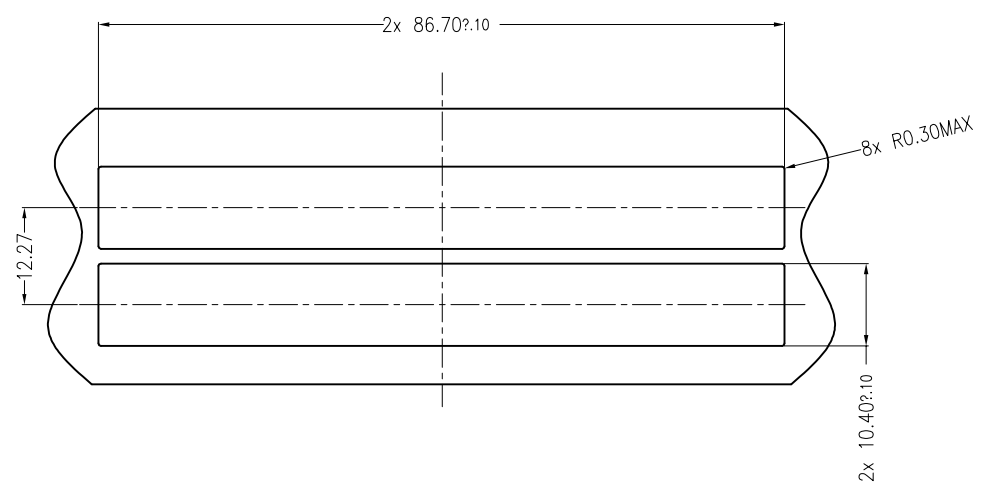

RECOMMENDED BEZEL CUT-OUT BELLY TO BELLY APPLICATIONS

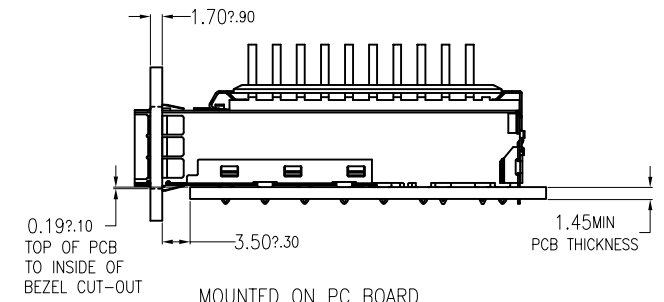

MOUNTED ON PC BOARD
SHOWN THRU RECOMMENDED BEZEL

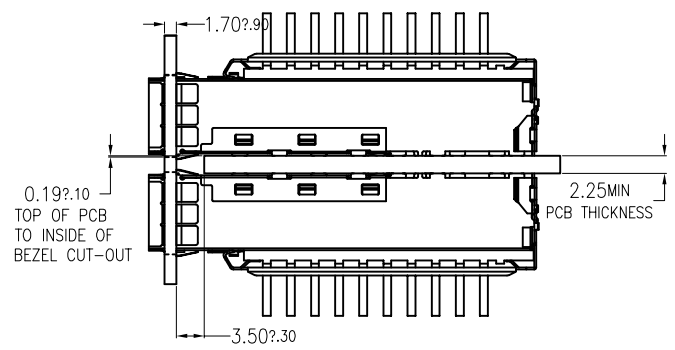

MOUNTED BELLY TO BELLY ON PC BOARD
SHOWN THRU RECOMMENDED BEZEL

X2	update drawings	/	NEIL	
版次	修改说明	ECN 编号	核准	

自由公差				设计	
长度尺寸	角度尺寸				
x. ±0.25	x' ±0.5'				
.XX ±0.25	.X' ±0.5'				
.XX ±0.20	.XX' ±0.5'				
.XXX ±0.15					
单位	mm	比例	1:1	核准	
A4	⊕	页次	3of5		

深圳市益晟康科技有限公司
ETLINK SHENZHEN ETLINK TECHNOLOGY CO.,LTD

品名	SFP+ 1x6 CAGE WITH HEATSINK
料号	81-116-00012-1
图号	E81151214 01-C
版本:	X2

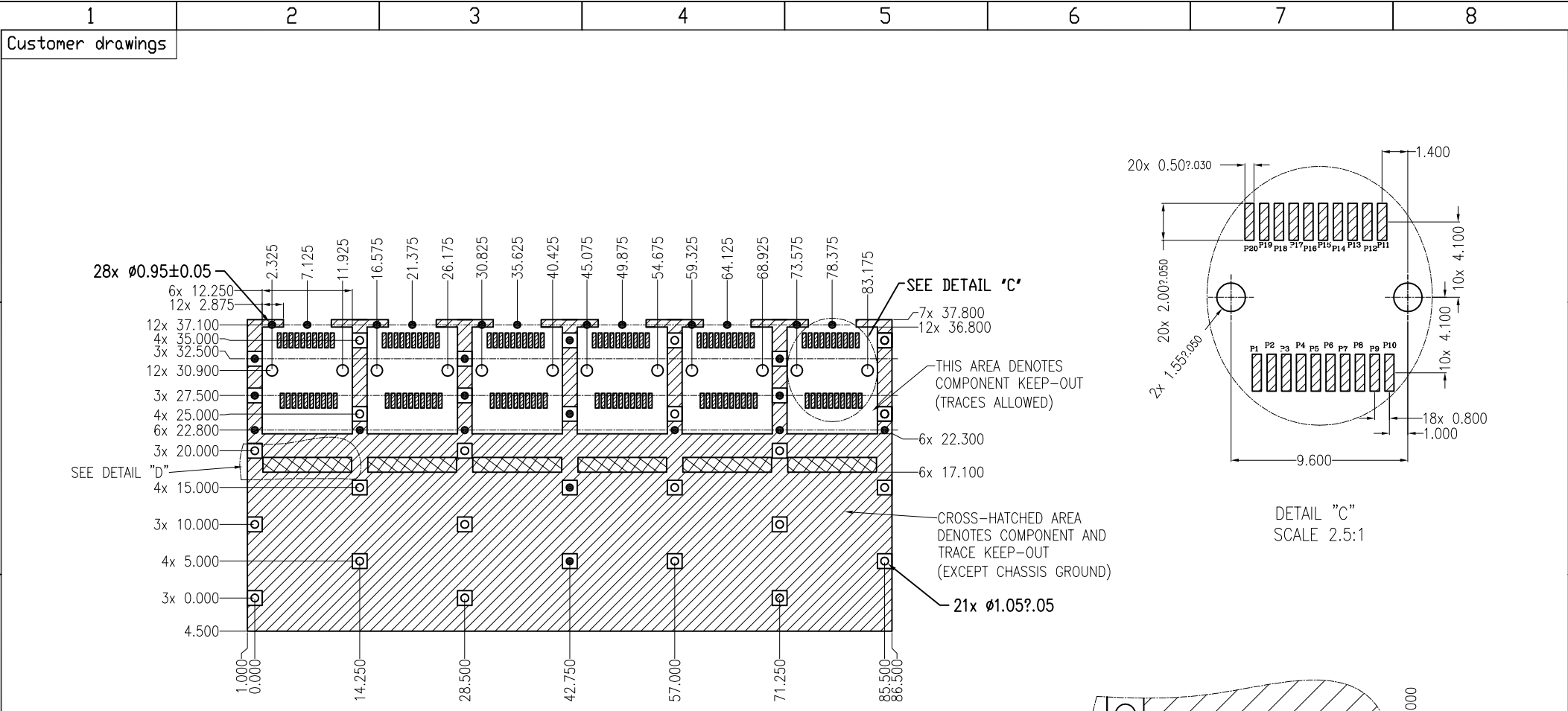

RECOMMENDED PCB CONFIGURATION WITH KEEP-OUT AREAS
SINGLE SIDED APPLICATONS

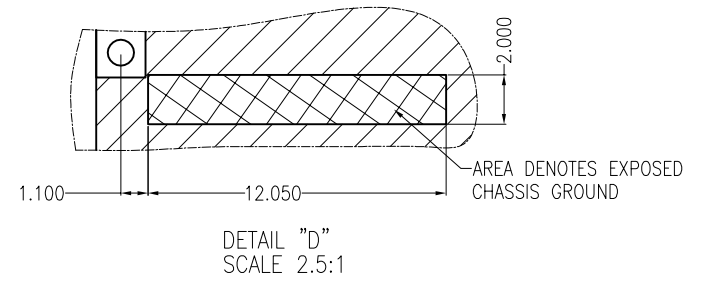

DETAIL "D"
SCALE 2.5:1

				自由公差		设计		深圳市益晟康科技有限公司 ETLINK SHENZHEN ETLINK TECHNOLOGY CO.,LTD					
		长度尺寸	角度尺寸										
		X.	±0.05	X'	±0.5°	审核		品名 SFP+ 1x6 CAGE WITH HEATSINK					
		.X	±0.05	.X'	±0.5°								
		.XX	±0.05	.XX'	±0.5°								
		.XXX	±0.05			核准		料号 81-116-00012-1					
X2	update drawings	/	NEIL	单位	mm					比例	1:1	图号 E8115121401-C 版本: X2	
版次	修改说明	ECN 编号	核准	A4	页次					4 of 5			

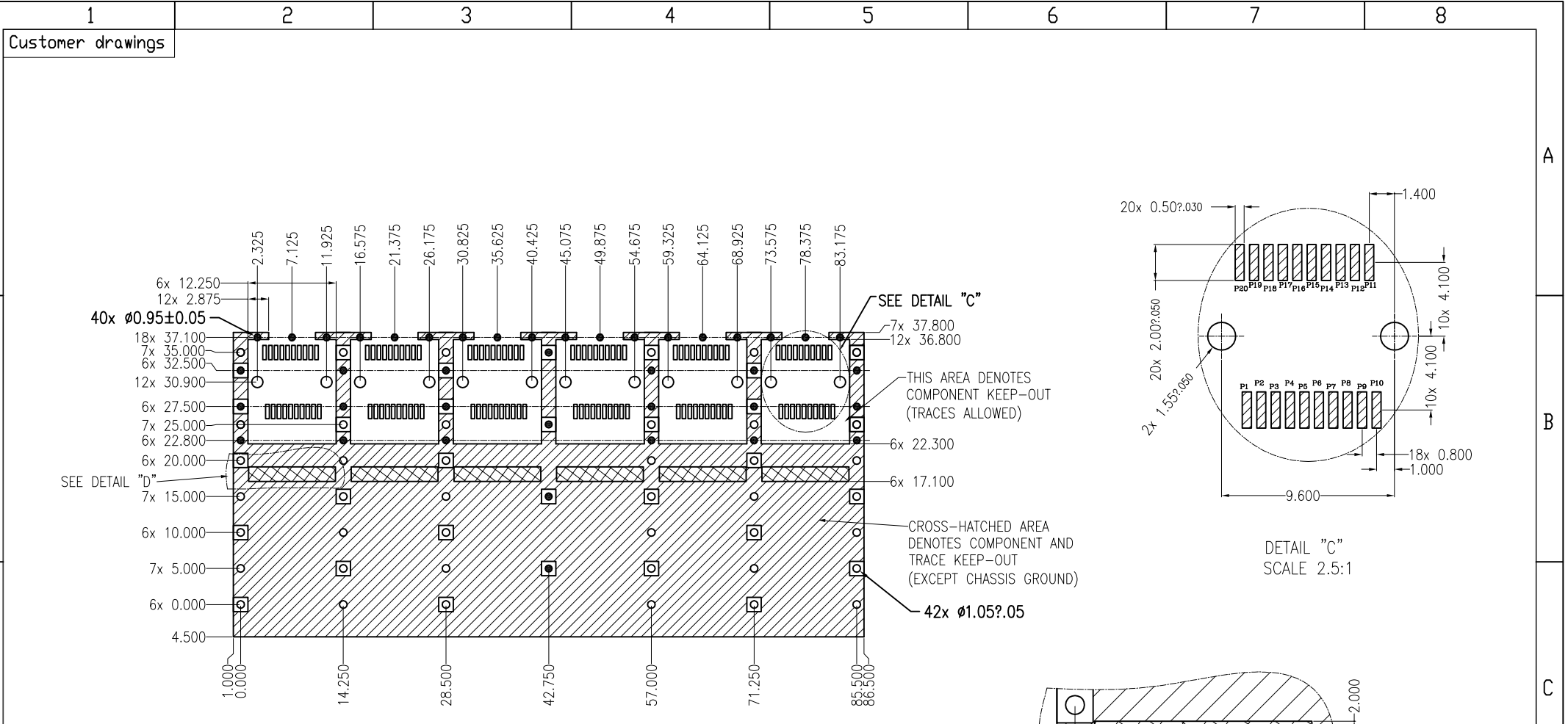

RECOMMENDED PCB CONFIGURATION WITH KEEP-OUT AREAS BELLY TO BELLY APPLICATIONS

DETAIL "C" SCALE 2.5:1

DETAIL "D" SCALE 2.5:1

自由公差		设计	
长度尺寸	角度尺寸	审核 核准	
X. ±0.05	X' ±0.5°		
.X ±0.05	.X' ±0.5°		
.XX ±0.05	.XX' ±0.5°		
.XXX ±0.05			
X2	update drawings	/	NEIL
版次	修改说明	ECN 编号	核准

深圳市益晟康科技有限公司 ETLINK SHENZHEN ETLINK TECHNOLOGY CO.,LTD	
品名	SFP+ 1x6 CAGE WITH HEATSINK
料号	81-116-00012-1
图号	E81151214.01-C
版本	X2